

TUCUXI – An Intelligent System for Personalized Medicine: from Individualization of Treatments to Research Databases and Back

Alevtina Dubovitskaya
University of Applied Sciences
Western Switzerland,
Swiss Federal Institute of Technology,
alevtina.dubovitskaya@epfl.ch

Thierry Buclin
University Hospital,
Lausanne, Switzerland
thierry.buclin@chuv.ch

Michael Schumacher
University of Applied Sciences
Western Switzerland,
Sierre, Switzerland
michael.schumacher@hevs.ch

Karl Aberer
Swiss Federal Institute of Technology,
Lausanne, Switzerland
karl.aberer@epfl.ch

Yann Thoma
School of Eng. and Management,
Yverdon-les-Bains, Switzerland
yann.thoma@heig-vd.ch

ABSTRACT

Therapeutic Drug Monitoring (TDM) is a key concept in precision medicine. The goal of TDM is to avoid therapeutic failure or toxic effects of a drug due to insufficient or excessive circulating concentration exposure related to between-patient variability in the drug's disposition. We present *TUCUXI* – an intelligent system for TDM. By making use of embedded mathematical models, the software allows to compute maximum likelihood individual predictions of drug concentrations from population pharmacokinetic data, based on patient's parameters and previously observed concentrations. *TUCUXI* was developed to be used in medical practice, to assist clinicians in taking dosage adjustment decisions for optimizing drug concentration levels. This software is currently being tested in a University Hospital. In this paper we focus on the process of software integration in clinical workflow. The modular architecture of the software allows us to plug in a module enabling data aggregation for research purposes. This is an important feature in order to develop new mathematical models for drugs, and thus to improve TDM. Finally we discuss ethical issues related to the use of an automated decision support system in clinical practice, in particular if it allows data aggregation for research purposes.

CCS CONCEPTS

• **Information systems** → **Expert systems**; • **Applied computing** → **Health care information systems**;

KEYWORDS

Automated TDM, personalized medicine, clinical information system, data integration

ACM Reference format:

Alevtina Dubovitskaya, Thierry Buclin, Michael Schumacher, Karl Aberer, and Yann Thoma. 2017. TUCUXI – An Intelligent System for Personalized Medicine: from Individualization of Treatments to Research Databases and Back. In *Proceedings of ACM-BCB '17, Boston, MA, USA, August 20-23, 2017*, 10 pages.

DOI: 10.1145/3107411.3107439

1 INTRODUCTION

Millions of people have to take a variety of medications every day. Unfortunately, treatments are not always effective in all patients. One reason for this is that different patients absorb, metabolize and eliminate drugs differently. Patients' response to a drug may depend on genetic makeup, age, body size, presence of kidney or liver diseases, drug-drug interactions, time of the day, etc. Therefore, the drug dose may be either insufficient and the patient will not benefit from the treatment, or excessive, which may cause serious toxicity. This is especially relevant to critical medications such as anti-cancer or anti-HIV drugs, which have both a narrow therapeutic range and a poorly predictable relationship between the dosage prescribed and the drug concentration exposure obtained in patients' blood.

For example, for the antiretroviral drug Rilpivirine used in the treatment of HIV patients, the target minimum concentration is 44ng/ml. However, it has been shown that on average four patients out of ten have Rilpivirine concentrations below the target. Therefore, a risk of insufficient efficacy exists in 40% of the patients treated with the standard dosage [2].

The problem of inappropriate dosing has been reported in medical literature [2, 4] and the TDM approach has been proposed as a corrective measure. TDM involves the measurement of drug concentrations in biological samples and the improvement of drug dosage to improve drug efficacy and reduce related toxicities [11, 16, 18]. TDM has evolved to become an important tool used for administration of antiarrhythmic and psychiatric drugs, anticonvulsants, anticancer agents, immunosuppressants, and antifungals [15].

Pharmacokinetic and pharmacodynamic (PKPD) models for numerous drugs are being developed by clinical pharmacologists to describe how the body handles a drug in terms of absorption, distribution, metabolism, and elimination (PK models). PD models then

Permission to make digital or hard copies of all or part of this work for personal or classroom use is granted without fee provided that copies are not made or distributed for profit or commercial advantage and that copies bear this notice and the full citation on the first page. Copyrights for components of this work owned by others than ACM must be honored. Abstracting with credit is permitted. To copy otherwise, or republish, to post on servers or to redistribute to lists, requires prior specific permission and/or a fee. Request permissions from permissions@acm.org.

ACM-BCB '17, Boston, MA, USA

© 2017 ACM. 978-1-4503-4722-8/17/08...\$15.00

DOI: 10.1145/3107411.3107439

describe how a drug affects the body by linking the drug concentration profile to one or several efficacy metrics. PKPD models are ideally suited to summarize the background knowledge necessary to adjust the drug dosage in a given patient [15].

However, in everyday clinical practice, it is fairly difficult for a clinician to make use of these PKPD models available only in scientific literature, and to apply them in every specific patient's case. A consultation with a pharmacologist may not be arranged shortly and will require the pharmacologist to collect a sufficient amount of information on the patient's clinical history before issuing a valid recommendation for dosage adjustment. Still an appropriate correction of drug dosage may be of critical importance if concentration exposure is significantly away from the targets ensuring optimal treatment efficacy and tolerability.

In order to address these issues, an automation of TDM is proposed. Existing software for TDM computer assistance has been surveyed by Fuchs et al. [10]. However, an intelligent system integrated in everyday clinical practice, allowing precise and rapid evaluation and adjustment of drug dosages, and simultaneously making the data available for the development of new PKPD models, is still missing.

Our development had to address the following challenges:

- *Interdisciplinary collaboration.* Mathematical models developed by researchers in clinical pharmacology need to be embedded in a user-friendly software suitable to be used by medical doctors/pharmacologists.
- *Ergonomy.* The software has to efficiently help medical doctors and pharmacologists by being well suited to the actual processing flow of TDM requests faced daily.
- *Medical device certification.* According to current regulation, such a system is a medical device and as such needs to be certified in order to ensure proper functionalities without risks of harming patients.
- *Interoperability.* The software requires seamless insertion into the existing network of electronic medical records, laboratory information system and other medical application, thus raising issues related to different interfaces, data formats, comprehensive clinical data flow etc.
- *Data aggregation for research.* The collection of population data from daily use of the software would be ideally suited to improve existing models and to develop new PKPD models for drugs candidate to TDM. However, patients' data are sensitive, studies may have very different scopes, and data aggregation is time consuming.
- *Ethical issues.* Automated processing of TDM raises a question of medical liability regarding highly sensitive aspects of patients' management such as dosage decisions.

In this paper we present *TUCUXI* – a software that was developed and integrated into the clinical data flow in order to provide automated dosage evaluation and adjustment decisions to assist pharmacologists or medical doctors. The modular architecture of the software allows to plug in dedicated modules for data aggregation for research purposes. These data are to be used by researchers to improve or develop PKPD models for TDM.

The advantages of our solution are the following ones. First, it provides *personalized dosage adjustment advice* based on reference

population PKPD data, patient's individual characteristics and concentrations previously observed, if available. Second, it *optimizes TDM procedures* and thus enables to process large numbers of requests; therefore it contributes to extend the use of TDM and the number of patients that may benefit from TDM services. Third, it provides an interface with other clinical applications, and could be easily *integrated into primary care and also used for medical research*. Finally, our solution also allows to *decrease the risk of human mistakes*.

The rest of the paper is organized as follows. In Section 2 we present current non-automatized processes of routine TDM in hospital settings and its difficulties. We describe the developed software in details in Section 3 along with its integration into the clinical data flow in Section 4. In Section 5 we discuss how the software enables data aggregation for research purposes. In Section 6 we discuss ethical issues related to the use of an automated software in clinical practice, to its validation, and to the aggregation of sensitive patients' medical data to improve TDM and therapeutic outcomes. We compare our software with currently existing solutions in Section 7 and we eventually express our conclusions about the evolution of TDM in Section 8.

2 TDM IN CLINICAL PRACTICE

Non-automated therapeutic drug monitoring, as currently practiced in most places, is a comprehensive and rather slow process. We studied the related procedures in actual medical practice at a University Hospital, where clinical pharmacologists work on a daily basis to provide dosage adjustment advice to medical doctors working either in the same hospital or elsewhere in the country.

The sequence diagram shown on Figure 1 (a) describes non – automated TDM¹. The process begins when a patient starts receiving treatment with a drug considered to require TDM. In this case, after a couple of intakes, a blood sample is drawn to monitor the plasma concentration of the drug. The medical doctor in charge of the patient prescribes the test and requests to send the patient's sample together with appropriate data to the laboratory, where concentration measurements are performed (steps 1 – 5 of the diagram on Figure 1a). Then, next step (6): the data are transferred into a laboratory information system, where they are stored and will be accessed by the pharmacologist in charge of clinical interpretation of the measurement result, after its validation.

When the pharmacologist receives a request to interpret a drug concentration value, as already mentioned above, he needs to collect a certain amount of medical information regarding the patient's case. To do so, he may need to access multiple databases that store information about the patient's clinical history, medication records, laboratory results, etc. (steps 7 – 12). The pharmacologist will also need to refer to PKPD models for the drug existing in the scientific literature (as step 15 indicates it). If any information about the patient is missing, a phone contact with the medical doctor that initiated the TDM request is also needed (steps 13 – 14).

When all the information is collected, the pharmacologist elaborates an interpretation of the laboratory result (16). At present,

¹In order to simplify graphical representation of the processes on both sequence diagrams on the Figure 1 we do not show existing interfaces and proxies that can be modeled as boundary object and control objects and placed between actors and entity objects on the UML diagram.

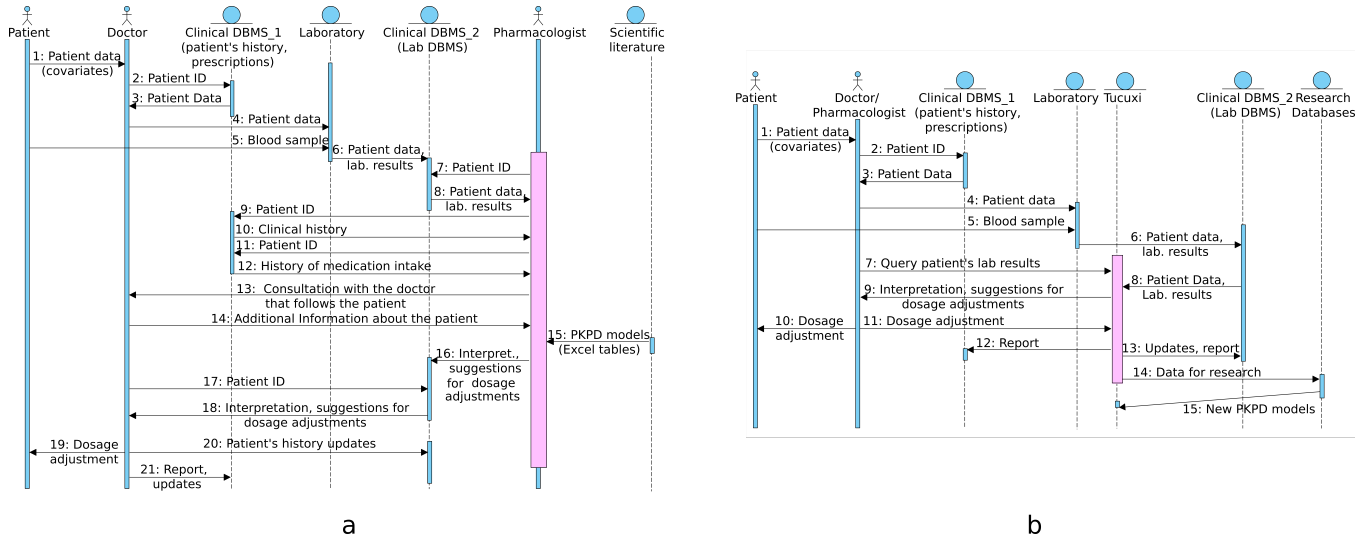

Figure 1: TDM in clinical practice: non-automatized process (a), TUCUXI (TDM software) integrated in clinical practice (b).

this is essentially made on an empirical basis. Some rare pharmacologists rely on models built up with custom tools (such as Excel), which can accommodate patient’s medical characteristics and just one or sometimes two concentration measurements. Only a small minority of centers regularly use one of the commercially available dedicated software tools, considered of insufficient ergonomoy for implementation in everyday routine [10]. The results and updates are sent to the hospital electronic medical record, which the physician that initiated the TDM request can now access (as presented by steps 16 – 21).

While working on each particular patient case, a pharmacologist has to access multiple sources of data, perform various estimations or calculations, switch contexts. Not only are current procedures slow and poorly efficient, but they also may increase the risk of human mistakes, which could significantly affect patient’s condition.

When clinical pharmacologists are not available in the hospital, most laboratory results are sent without interpretation to the physicians that have requested TDM. Most physicians tend to translate TDM results into dosage adjustments according to an empirical trial-and-error strategy – which should not be entirely denigrated though, as it often fits clinical needs to a sufficient extent. In exceptional cases another institution will be contacted (such as the Hospital we are collaborating with). However, this may cause even longer delays due to the need to transfer the data, to clarify missing details about patient’s history (due to the lack of interoperability between different hospitals, e.g., data stored in an hospital can only be accessed internally due to their sensitive nature), and to elaborate the pharmacological interpretation requested.

In order to optimize highlighted steps 7 – 20 of the diagram on Figure 1a, and to tackle the difficulties listed above, we propose to integrate a TDM software in the clinical data flow. The software provides an interface that guides the user through the TDM process, provides required information about the patient and employs PKPD models built up using population data and integrated into the software. This allows not only to interpret the current concentration

value but also to predict future drug exposure, and to suggest a personalized dosage adjustment for the patient. Figure 1b presents the sequence diagram of the data flow using TDM software TUCUXI integrated in clinical practice. One can notice that the flow is simplified (steps 7 – 13), and also includes populating a research database for building up new PKPD models (steps 14 – 15).

3 TUCUXI AND EMBEDDED MATHEMATICAL MODELS

A software helping the clinicians in their daily practice can be conceived as a standalone software embedding a graphical user interface (GUI) or as a service hidden behind a client. We present here the GUI version, and we will discuss the service possibilities in Section 6.

3.1 Software Description

TUCUXI core capabilities can be segmented into three main parts:

- (1) Computation of concentration percentiles and comparison with therapeutic targets, based on the patient’s dosage regimen and clinical characteristics, as well as on reference PKPD data ;
- (2) Computation of concentration predictions based on the same data confronted with the patient’s observations ;
- (3) Suggestion of dosage adjustments in order to drive the resulting concentration exposure into the therapeutic targets.

The general architecture is made of layers. The first layer is pure mathematics, implemented in a very optimized way. It ensures the three core capabilities listed above. The second layer (processing layer) is responsible for translating Domain Model Objects into mathematical objects and then calling the math functions. On top of this second layer the GUI exploits the processing layer and an interconnection module to create the final software.

The following subsection gives some insight corresponding to the three main mathematical software parts.

3.2 Mathematical Engine

3.2.1 Concentration calculation. Prediction of drug concentration can be done through model-free systems (e.g., Support Vector Machine [23]) based on population data, or through model-based systems. The model-free approach may be well suited for predicting concentration at a specific time (typically time of measure), but often suffers from limits of applicability (depending on the method, concentrations below zero could be calculated). The model-based approach is more suited for continuous curves, and is used by a majority of pharmacologists (also because it allows to *explain* the calculation in a physiological way).

The concept is to model the human body in terms of compartments exchanging substances. The drug concentration is typically measured in blood, so a central compartment corresponds to the entire blood veins and arteries. Models can have more than one compartment, and if such, the muscles are a typical second compartment. Taking a drug is seen as an input to a specific compartment, and the drug elimination corresponds to a flow leaving one of the compartments. Figure 2 represents a 2-compartment model for bolus injection.

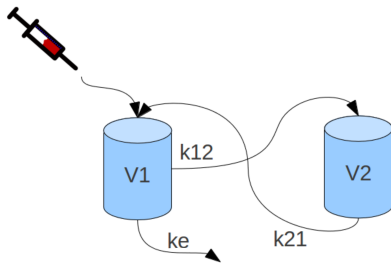

Figure 2: 2-compartment model

Constants k_e , k_{12} , k_{21} are used to describe the flow between the compartments. For example, here the differential equations are, for concentration C_1 and C_2 , respectively in compartments V_1 and V_2 :

$$\begin{aligned}\frac{dC_1}{dt} &= k_{21}C_2 - k_{12}C_1 - k_e C_1, \\ \frac{dC_2}{dt} &= k_{12}C_1 - k_{21}C_2.\end{aligned}$$

It is to be noted that in this case, administrating a drug consists in adding a certain amount at the time of administration in compartment V_1 .

The constants are directly derived from population studies, typically published by pharmacologists for a specific set of patients. The equations presented above exploit so-called micro-constants that are calculated from macro-constants (clearance, volume, ...). Depending on the complexity of the differential equation, analytical solutions are available and more efficient in terms of computation time. For linear elimination models up to 3 compartments, such analytical solutions exist, but for other models (e.g. Michaelis-Menten [17]) only differential equations are available.

The macro-constants and the dosage history define exactly the prediction curve shape. The question is then about the way of evaluating these constants.

From a population pharmacokinetics study, the authors usually present parameters (macro-constants), their variability, consisting in inter-individual variability, an intra-individual variability, and the influence of patient covariates onto the parameters.

Based on this data, *TUCUXI* can first calculate predictions for the so-called *typical patient*. For each study, the average parameter values correspond to such a typical individual, and if no information is available about a patient, this calculation gives a first approximation of what could be the observed concentration based on the medical drug intakes.

If patient's covariates are known, the published models propose to adapt the average parameters thanks to update functions. This kind of adaptation is referred to as *a priori* calculations and results in a prediction reflecting more precisely the concentrations expected for a specific individual. Typical covariates are age, gender, or weight, but *TUCUXI* can handle any kind and number of covariates for a specific model.

Finally, the most accurate prediction is made when, in conjunction with covariates, the software "knows" the results of real concentration measurements done at specific times. The method currently implemented is based on a maximum likelihood function mixed with a Bayesian approach. It allows to take into account the population statistics as well as the measures, by exploiting the intra- and inter-individual variability. The resulting *a posteriori* prediction is the one used for the dosage adjustment.

3.2.2 Percentiles calculation. While prediction is at the core of *TUCUXI*, percentiles are essential in order to evaluate the normality of a patient response with respect to the population. Percentiles are calculated thanks to a Monte Carlo simulation exploiting the intra- and inter-individual variability. A particular attention was put on the implementation of this part of the software, as Monte Carlo simulations can be very slow. An in-depth optimization allows to calculate useful percentiles in around a second on a standard PC.

Typically these percentiles allow to evaluate the likelihood of a specific concentration measurement and will help the pharmacologists to better interpret the supplied result.

3.2.3 Dosage adjustment. Finally, *TUCUXI* not only calculates predictions and percentiles, but also can propose dosages adjustments. The software can issue recommendations on the amount of drug to be administrated, the interval between intakes, and on the infusion time in case of infusion intake. So, up to three values can be fitted to match the best treatment for a specific person. The goal is that concentration predictions actually match therapeutic targets. These targets can be of various types: (1) residual concentration (before the next intake), (2) peak concentration (typically 1 hour after the intake), (3) mean concentration, and (4) area under the curve (AUC). Fitness functions for each specific targets have been designed and are used to find the best combination of dose-interval-infusion. A score is therefore given to each combination and can be used to select the best candidates. It is to be noted that for each medical drug, a selection of discrete values is available so as to reduce the search space and more importantly to keep the treatment feasible. For instance, the authorized intervals are 8, 12, 24 and 36

hours and the doses correspond to the available drug formulations (e.g. pills, tablets, capsules), or possibly simple fractions of them (e.g. scored tablets).

3.3 Interface for Clinicians

TDM as performed every day in specialized institutions is based on custom tools and needs to be done rapidly in order not to cost too much time (and money for the institution). There is a real need for a software facilitating the clinicians' decisions. Therefore *TUCUXI* has been designed in close collaboration with pharmacologists. It reflects their thinking while performing TDM interpretation.

Figure 3 shows the GUI. The work flow is represented thanks to the buttons allowing to navigate through the various screens (or panels). Each button corresponds to a specific screen showing information related to a particular part of the process.

It is important to differentiate two use cases of the software:

- (1) **Standalone.** A non-connected use where the user has to enter all the data by himself.
- (2) **Connected.** A connection to an institutional database allows to retrieve a full set of data (cf. Section 4).

The two flows are run on the same GUI with the difference being that for the second use case the user mostly has to acknowledge the correctness of data instead of filling himself the forms. It is interesting to notice that the connected flow could be totally automated, except for the suggestions writing by the medical doctor. This automation corresponds to a server version without human interaction, as discussed later in Section 6.

The flow, corresponding to the current pharmacologists practice is decomposed into 9 panels, shown from left to right on the GUI (cf. Figure 3). They are described in the following lines, with some information about differences between the standalone and the connected flow.

- (1) **Patient information.** This panel simply allows to check and complete if necessary administrative data about the patient. The most important part here is the birth date, as most of the models use this information as a covariate.
- (2) **Medical drug selection.** For a standalone use, the user has to select the medical drug (the active substance), and the model to be used. This model can be dependent on the patient information (Caucasian or not, neonate, child or adult, for instance). For the connected use, the active substance is already defined, and only the model needs to be selected. This model selection could be automated in the future, based on patient data if available.
- (3) **Dosages.** Past dosages are introduced within this panel. For a connected use, these fields can be fed from the electronic medical record.
- (4) **Patient covariates.** Patient covariates are sensitive information. The models exploit them in order to more accurately predict the expected drug concentration. In standalone mode, the covariates used by the selected models are displayed and can be modified by the user, while in connected mode, most of these variables are automatically retrieved from the electronic medical record. The prediction curve displayed on this panel corresponds to the *a priori* prediction, with the corresponding percentiles.

- (5) **Drug concentration measurements.** Observed concentrations are defined within this panel, or automatically fetched. From this panel up to the end of the flow, the prediction curve corresponds to the *a posteriori* prediction, taking into account the covariates and the past measurements.
- (6) **Targets.** Before proposing an adjustment, the software allows to validate or modify the target concentrations. In most cases the default target values of the medical drug will be used, but if the physician has more patient's information that could affect the desired targets he can modify them.
- (7) **Adjustment.** Based on all data filled up to this point, *TUCUXI* can propose an automatic drug dosage adjustment. Valid propositions are displayed in a list sorted by accuracy. The user can then select the most appropriate, which will be submitted as a recommendation and added to the list of dosages.
- (8) **Validation.** After the selection of the best adjustment, the user can enter text that will be appended to the final report. Five different fields serve to guide the type of information required: expectedness, suitability, prediction, remonitoring and warning.
- (9) **Report generation.** Finally, a report is automatically generated. It contains all data about the patient, a prediction curve, the kinetic parameters, and the text entered by the user. A PDF file can then be exported and potentially sent to the medical records database.

As *TUCUXI* is a medical device, ensuring that data are correct is highly important. In standalone mode, it is reasonable to make the assumption that the user is responsible of filling the data correctly. However, in connected mode, almost all data are automatically retrieved from a database. The user needs to acknowledge he went through all the panels in order to validate the interpretation. The validation status is shown on each flow button (see yellow circles in figure 3). These buttons can have three states: invalid, valid and validated. Data retrieved from the database is marked as valid, except if some fields cannot be correctly casted, and the user has to click on the circle to validate it. In figure 3 the validation and report panels can not be accessed because the user did not yet validate the first 7 panels. The development team took this decision based on the risk analysis of the software, in order to ensure the user is aware of the data used to predict concentrations and to propose adjustments.

4 TUCUXI INTEGRATION IN CLINICAL PRACTICE

Usually, the pharmacologist receives a list of pending requests for TDM interpretation. He selects a request from the list to analyze the concentration of the drug and evaluate the dosage adjustment called for. For each request he needs to query additional specific information about the corresponding patient. In this section we describe the process of integration of the TDM software presented in the previous section in clinical data flow. First, we show how the interoperability was achieved. Second, we present data structure and messages designed to exchange the data.

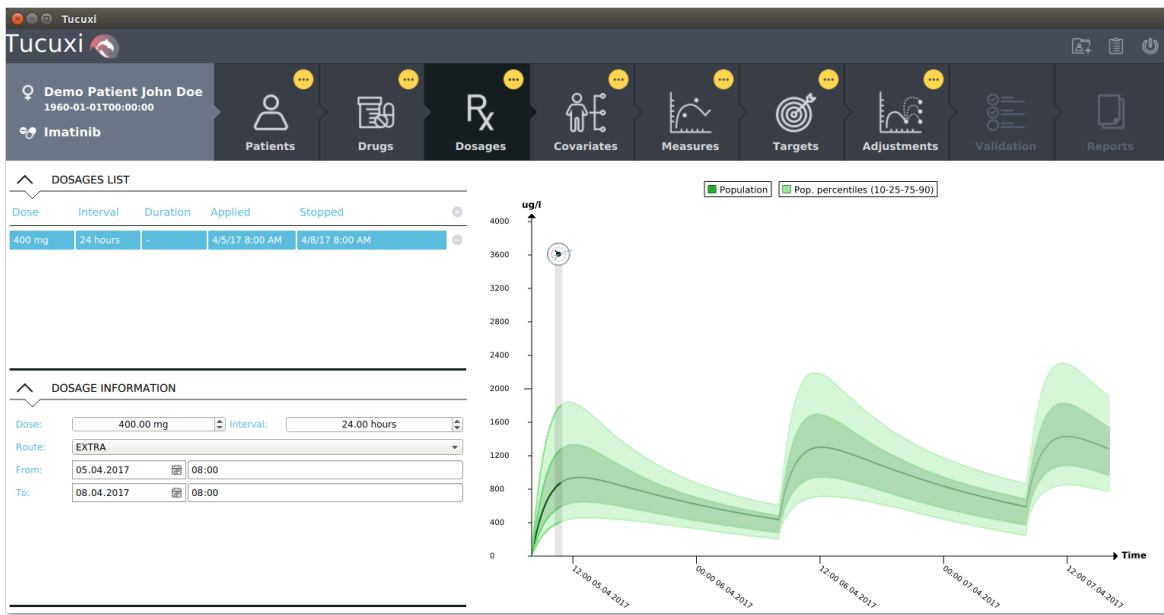

Figure 3: TUCUXI graphical user interface

4.1 Interfaces for data exchange

In order to integrate the TDM software described in Section 3 into the clinical data flow presented above we had to define how to exchange healthcare data between heterogeneous systems that support different data formats. Medical data are stored and exchanged between clinical databases in HL7 format. However, the software operates the data in XML format and produces the reports and graphs in PDF and PNG format. To solve this interoperability issue Mirth Connect² – an open source healthcare integration engine – has been used.

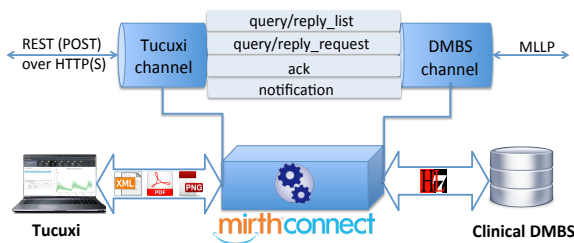

Figure 4: Communication between TUCUXI and the database of the medical institution

Figure 4 shows the actors involved in the process of data exchange and the formats of the data they use. We use a client-server architecture with a proxy to model communication between TUCUXI and clinical database management system (DMBS). We created two external channels for communications: one for TUCUXI-Mirth and one for DMBS-Mirth; and four channels were deployed

²<https://www.mirth.com>

on Mirth for the data transformations. To connect TUCUXI to another system there is no need to modify the software, only one Mirth channel may need to be adapted.

Communication between TDM software and proxy is done using a REST API. Sending a query or an update is initiated via an HTTP(S) request that encapsulates the corresponding message in XML format (cf. Figure 5). The client TUCUXI can send 2 types of query requests, an acknowledgment message (when a response is received) and a notification to update the DMBS. For each type of these messages the separate channel is deployed on the proxy and a message is filtered to the corresponding channel based on the message type. For all the messages sent by TUCUXI except the acknowledgment (there is no response for the ACK), the response will go through the same channel and will be transformed from HL7 format to XML. Transformations are defined separately using JavaScript for each type of message.

Communication between Mirth and clinical DMBS is defined according to the Minimal Lower Layer Protocol (MLLP) – a standard for transmitting HL7 messages via TCP/IP.

We have implemented the data flow as shown on Figure 5. The sequence diagram that describes the data flow consists of the following steps:

- (1) Obtaining the list of pending requests ;
- (2) Obtaining the detailed data about specific request ;
- (3) Individual dosage evaluation, adjustment proposition ;
- (4) Sending results to the medical database.

At the source/destination of these channels we deployed a transformer using JavaScript that perform the mapping and construct messages of each type required by the clinical flow. All the messages are received on an external channel that redirects the messages based on the filter defined with respect to the message header where the type of the message is specified.

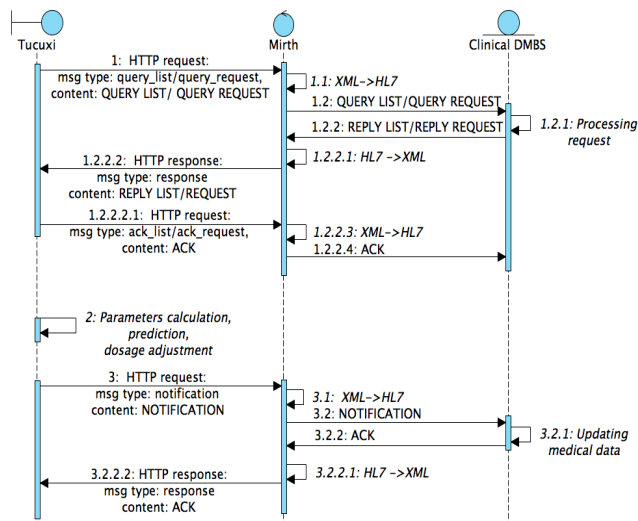

Figure 5: Communication diagram for the clinical data flow with TUCUXI

4.2 Data structure and messages

In this subsection we present the content of the messages we constructed for data exchange between TUCUXI and a clinical database. Following the clinical flow of TDM we need to provide the user of the software (doctor, or pharmacologist) with the list of pending requests. A user can specify a time frame that will be an inclusion criteria for the requests based on their arrival date. According to standardized procedures of routine non-automated TDM in the hospital a code “CPCL” with the value “4CPCL” (“0CPCL”) is used to tag whether request has (not) been already processed by a pharmacologist. Therefore in order to ask for the list of requests, a QUERY LIST message contains the time interval corresponding to the sampling arrival date/time and CPCL value: “0CPCL”.

A REPLY LIST message is a list of pending requests and it contains, for each request, the following information:

- request Id – a unique identifier of the request within the clinical system ;
- CPCL code value ;
- information about the patient such as covariates (gender and age), as well as address and the patient identifier in the clinical system ;
- practitioner data: information about the doctor that prescribed the test, and the medical institution, if the sample is sent by another hospital ;
- sample data: identifier of the sample (identifier of the tube form the laboratory), the date/time of the sampling and sample arrival date/time in the laboratory ;
- information about the drug: code used in the system, active principle, brand name, Anatomical Therapeutic Chemical (ATC)³ classification system code.

This information allows the pharmacologist to ensure that the samples with the medications that require urgent analysis are validated on time.

To obtain more information about the request selected for validation, the QUERY REQUEST message is sent to the clinical database system. Multiple drugs can be measured in one sample and several samples can correspond to the same patient. Therefore, a QUERY REQUEST contains the patient unique identifier, request id and drug id. This combination uniquely identifies a request for validation of the drug.

REPLY REQUEST message in comparison to QUERY LIST contains extended information such as the following:

- dosages: start of the treatment or the date of last change of dosage, date/time of the last dose intake, current dosage, frequency of intake, route of administration, comments provided by the clinician ;
- sample results, containing observed concentration analyte and corresponding value and unit ;
- additional patient’s covariates required for the drug model: bodyweight, renal failure (y/n), last creatinine, hemodialysis (y/n), hemofiltration (y/n), gestational age (for newborns), liver failure (y/n), childpugh, heart failure (y/n), lung failure (y/n), together with the value, unit and the date/time date of the covariate’s acquisition ;
- Timestamped clinical data such as clinical diagnosis, the adverse effects information (toxicity), indication that corresponds to the motivations to TDM, response.

While the REPLY LIST message contains the information that can help the clinician to review and choose next request to be validated, extended information from the REPLY REQUEST is used to fill in (or pre-fill) the panels (1)-(6) of the software. When a request is processed, and the report is generated, the NOTIFICATION message is sent to the clinical database with the following information:

- expectedness: the interpretation of the normality of the result by the analyst ;
- suitability of the treatment: the interpretation of the appropriateness of drug exposure by the analyst ;
- prediction: the recommendation of dosage adjustment by the analyst ;
- remonitoring: the recommendation for future monitoring by the analyst ;
- a priori and a posteriori parameters of the mathematical model ;
- some cautionary statement by the analyst and the timestamp of the interpretation ;
- image of the expected curve (in a binary format in base-64) ;
- report described in Section 3 generated automatically ;
- CPCL code with the value “4CPCL”, corresponding to the validated request.

If any information about the patient has to be modified (due to a possible mistake originated from clinical database) it can be updated using a NOTIFICATION message.

When TUCUXI receives a REPLY LIST or a REPLY REQUEST message an ACK message is sent to the clinical database to acknowledge reception of the messages from clinical DBMS. Reception of NOTIFICATION is acknowledged by the clinical DBMS as well.

³www.whocc.no/atc_ddd_index/

While constructing the messages with the the information listed above in HL7⁴ v2.4 format, custom segments were introduced. Custom segments were used to express status of the request (validated or awaiting validation), information about drug and dosages, some clinical data, the report and the curve with the predicted concentration, as well as a priori and a posteriori parameters of the mathematical model. For each query/reply pairs we define so-called Conformance Statement – the information that identifies the query, specifies what items can be queried and describes what the response will look like.

5 FROM DROP OF BLOOD TO RESEARCH DATABASE AND BACK

Research studies that use retrospective medical data have become a major source of contributions to the biomedical science literature [12]. Therefore, data aggregation for the research purposes is a essential step towards enhancing clinical literature, e.g., by developing new PKPD models.

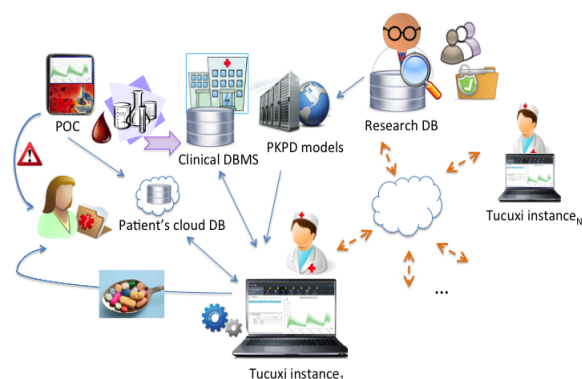

Figure 6: Connecting multiple instances of TDM software

Figure 6 shows the data flow in a healthcare system spanning from a patient bedside to the healthcare data aggregated in the cloud and used for the research purposes.

Characteristics of the data to be acquired for a research study are determined by the requirements of the study. Therefore, multiple databases need to be constructed. For this we need a system that will connect researchers and medical institutions and will allow them to collaborate with each other and will enable dynamic data aggregation. We assume that the number of data sources participating in the data aggregation should not be static as well as description of the data to be aggregated (could be adjusted during the process of data aggregation depending on the data availability) [6]. Dynamicity of such system will allow one to accelerate a notoriously time-consuming data collection process.

We developed a multi-agent system for dynamic data aggregation for the research purposes. An agent is modeled as an instance of *TUCUXI* used by a doctor or in a hospital. It has been tested using anonymized TDM data and presented in detail in [6].

In clinical practice unless the patient provided a consent for sharing the data as they are, the data have to be anonymized. We

⁴<http://www.hl7.org>.

also developed a privacy-preserving algorithm for distributed data aggregation for medical research [7] that can be used to ensure anonymity of the patients. However, anonymization may affect the utility of the data. To overcome this issue we are currently evaluating an algorithm that will allow to improve the data utility with the database growth while preserving patient's privacy.

Expanding TDM to a larger patients population by making it available at the Point-of-Care (POC) system will further advance the outcome of drug therapies. Key for widespread dosage adjustment is the availability of point-of-care devices able to measure plasma drug concentration in a simple, automated, and cost – effective fashion. Cappi et al. introduce and test such POC device. The authors present a portable, palm-sized transmission-localized surface plasmon resonance (T-LSPR) setup, comprised of off-the-shelf components and coupled with DNA-based aptamers specific to the antibiotic tobramycin [5]. Mobile version of the software e.g., running on the POC (cf. Figure 6) or on the tablet connected to POC, can be used to alert a patient in case of toxicity or inefficacy of the treatment and provide a recommendation to ask for medical assistance. Dosage adjustment can be made faster as there is no need to send the blood sample to a laboratory and to wait for the results to be transmitted back [5]. The results from POC could also be sent to the patient's cloud database, accessed by the clinician or pharmacist and analyzed using TDM software.

6 DISCUSSION

In this section we discuss the ethical issues related to the use of automated software to manage patient's healthcare data.

6.1 Ethical issues

6.1.1 Decision making in medical domain. A piece of software like *TUCUXI* does not aim to replace physicians, but rather to provide assistance in TDM. Dosage individualization is suitable or even required for many drugs, but it is difficult and time consuming, the way it is done at present. Current tools such as Excel worksheets or non-ergonomic softwares are not well suited to manage heterogeneous patients' data in order to issue dosage adjustment decisions on a large scale. Moreover, the time required for a consultation with a clinical pharmacologist may delay important adjustments of the treatment. We think it is possible that clinicians use our software without consulting a specialist in pharmacology. For this we need to ensure "safety" of the software, i.e. its ability to detect unusual cases and to produce reports of no worse quality than those produced by trained clinical pharmacologists.

Before using any PKPD model for a given drug, the model will require approval by a trained pharmacologist after thorough testing. A semi- or fully-automated procedure may contribute to efficient validation of such drug models in the future. Certification of the whole software along with its reference PKPD database is required. Currently we are developing the necessary trials to make it a validated medical device according to applicable regulation.

6.1.2 Evaluation of *TUCUXI* as a TDM software. A recent review [19] describes four steps to implement pharmacometrics-based decision support tools, consisting of validating scientific components, defining technical options, considering regulatory aspects, and achieving efficient commercialization. Examples of

pharmacometrics-based decision tools that support monitoring of patients and individualization of treatment strategies in neonates, children and adults are presented. Concretely, the evaluation of a medical software such as *TUCUXI* requires several tasks:

- (1) Verification of the **Correctness of implementation of mathematical models**, for instance, using automated mathematical validation of the software against NONMEM – the *de facto* standard for studies in pharmacokinetics [3].
- (2) **Validation of data exchange** through a series of scripts aiming to obtain the list of pending TDM requests, run multiple times a day.
- (3) While the first two tasks are being run automatically every day, thanks to scripting facilities, **clinical validation** requires a real validation in clinical practice. An evaluation protocol has been designed and is meant to be used after the first two tasks proved the correctness of the software.

6.1.3 Fully automated TDM. While the GUI version of *TUCUXI* is currently being tested, a next server version is under development. Its goal is to be able to propose an automated interpretation based on all data sent to the server. Basically it is meant to work as the GUI version, but automatically calculating predictions and dosage adjustments. A report will be generated, with graphs and a list of best dosage candidates for the specific patient. This server will allow to be integrated into an electronic patient infrastructure, as a service for analysis labs. Ethically speaking, a human should still be responsible to check the report and to choose the best dosage.

6.2 Patient's privacy

Having access to the population data is crucial for building new mathematical models, or improving characteristics and parameters of the existing ones. According to the current data protection legislation in US⁵ and in Europe [9], as well as to the EU General Data Protection Regulation (GDPR) that will replace the European Data Protection Directive 95/46/EC starting from 25 May 2018⁶, collecting and sharing personal data require signed consent from the patient to allow using his data for research purposes. Not all patients are willing to provide consent due to the risk of their data misuse [21, 22]. For example, if the healthcare data become publicly available insurance companies may infer that a person has a chronic disease susceptibility, and may refuse an application or reject the renewal of their insurance policy. An employer may try to infer healthcare information about potential employees and based on the sensitive information (a serious health condition or a chronic disease susceptibility) may discriminate the candidate [6]. As an alternative to the consent collection, the data can be anonymized: the patient's data to be used for the research must not be linked to the identity of a person to whom these data belong [8, 9].

How to ensure that the data that may belong to the same patient and were aggregated from different sources were properly anonymized? In [7] the authors proposed a privacy-preserving algorithm for independent release of medical data in distributed environment. However, one should take into account that absolute anonymization is only possible when no data are shared at all and,

therefore, the privacy-utility trade-off needs to be found for every specific case. How to automatically adapt this trade-off for different databases? What is an acceptable risk of violation of patient's privacy? These questions still remain open.

7 RELATED WORK

Fuchs et al in [10] present a review of twelve available clinical pharmacokinetic computer tools. The authors also describe the history and evolution of the software dedicated to monitoring and dosage adjustment starting from the software developed by Laboratory of Applied Pharmacokinetics at the University of Southern California (Los Angeles, CA, USA), launched in 1973 [14], and evolved to the *BestDose*⁷ to the available⁸ software packages such as *MwPharm* [20] and *TCIWorks* [25] that turned out to be the best ranked TDM programs according to the review [10].

MwPharm has the largest database of drugs with their pharmacokinetic properties and almost 300 population models embedded in the software. However, similarly to *BestDose* it is also a standalone TDM software. This means that the patient's data have to be manually inserted, and dosage adjustments are not automatically in patient's medical record, they will be stored in the local databases. However, according to [10] none of these programs, including *BestDose* and *TCIWorks* yet fulfills all of the requirements to clinical pharmacokinetics computer program.

During last years (since the review of Fuchs et al. from 2013 [10]) few TDM software tools have been developed. *TDMx* is a novel web-based open-access support tool for optimising antimicrobial dosing regimens in clinical routine [24]. *TDMx* is not a registered or certified medical device. As result of a research project, *TDMx* is provided for personal use only, the accuracy of the provided results can not be guaranteed⁹. Currently, *TDMx* is available for only 4 drugs (meropenem, piperacillin, amikacin and gentamicin).

NextDose is an online dose calculator that uses Bayesian non-parametric approach to propose dose regimens after concentration measurements become available. The software consists of three abstraction layers and provide a clear separation between the user interface, model controllers and the modeling software. *Doseme*¹⁰ and *insightrx*¹¹ are recently available commercial software for TDM.

However, unlike *DoseMe* and *NextDose*, *TUCUXI* allows to calculate population, a priori and a posteriori percentiles. Moreover, the authors in [1] claim that presently available software (such as *DoseMe*, *insightrx* and *NextDose*) is still sufficiently complex and requires training to enable rapid use at the bedside by healthcare professionals. In contrast, *TUCUXI*– TDM software presented in this paper – has a very intuitive user interface, that makes the software easy to use by non-pharmacologists. It can be integrated in clinical practice, and can also be connected to the research database.

8 CONCLUSIONS

Therapeutic drug monitoring allows to individualize the dose and helps to ensure the best possible outcome for each patient [13].

⁵<http://www.hhs.gov/hipaa/>

⁶<http://www.eugdpr.org/eugdpr.org.html>

⁷<http://www.lapk.org/bestdose.php>

⁸at the time of preparing the review, year 2013

⁹<http://www.tdmx.eu/>

¹⁰<https://doseme.com.au/science-behind-doseme>

¹¹www.insight-rx.com

However, there is still a number of challenges that have to be overcome before individualized drug dosing based on TDM is widely used [1]. Software tools developed to automate the process of TDM are evolving. However, a solution with comprehensive clinical and research capabilities, showing simplicity, flexibility and user friendliness is still in demand [10].

In order to address this need and improve dosage adjustment procedures, *TUCUXI*, an intelligent automated system, spanning from the patient's bedside to research databases has been developed. This interactive tool is designed to guide a user through the process of TDM and, therefore, can be used not only by clinical pharmacologists but also by general practitioners and possibly by educated patients. We presented the functionalities of the system, user interface, as well as interfaces and messages developed to achieve interoperability with clinical DMBS and successful integration in clinical practice.

Correctness of mathematical models embedded in the software, as well of reliability of data exchange have already been verified. Currently real world trials to certify the software as medical device are being developed. Clinical validation by practitioners will follow. Moreover, *TUCUXI* software can be used to combine patient care and clinical research by exporting the data for developing new PKPD models. We also envisage the usage of a mobile TDM software embedded in a point-of-care "lab-on-chip" system, that will further advance the outcome of drug therapies. In this work, we also addressed a number of challenges and discussed ethical issues related to automation of therapeutic drug monitoring in patient care and medical research.

ACKNOWLEDGMENTS

This work was evaluated by the Swiss National Science Foundation, financed by the Swiss Confederation and funded by Nano-Tera.ch, in the framework of an RTD project ISyPeM2: developing therapeutic drug monitoring by designing a point-of-care system to measure drug concentration in blood samples and adjust dosage accordingly. The authors would like to thank all the software developers that allowed *TUCUXI* to be successful. They also wish to thank Séverine Petitprez for helpful discussions and anonymous reviewers for their comments.

REFERENCES

- [1] Basma Al-Metwali and Hussain Mulla. 2017. Personalised dosing of medicines for children. *Journal of Pharmacy and Pharmacology* (2017).
- [2] Manel Aouri, Catalina Barcelo, Monia Guidi, Margalida Rotger, Matthias Cavassini, Cédric Hizrel, Thierry Buclin, Laurent A Decosterd, Chantal Csajka, Swiss HIV Cohort Study, and others. 2017. Population Pharmacokinetics and Pharmacogenetics Analysis of Rilpivirine in HIV-1-Infected Individuals. *Antimicrobial Agents and Chemotherapy* 61, 1 (2017), e00899–16.
- [3] AJ Boeckmann, LB Sheiner, and SL Beal. 1994. NONMEM users guide. *San Francisco: University of California San Francisco* (1994).
- [4] Olivier Capitain, Andrea Asevoaia, Michele Boisdron-Celle, Anne-Lise Poirier, Alain Morel, and Erick Gamelin. 2012. Individual fluorouracil dose adjustment in FOLFOX based on pharmacokinetic follow-up compared with conventional body-area-surface dosing: a phase II, proof-of-concept study. *Clinical colorectal cancer* 11, 4 (2012), 263–267.
- [5] Giulia Cappi, Fabio M Spiga, Yessica Moncada, Anna Ferretti, Michael Beyeler, Marco Bianchessi, Laurent Decosterd, Thierry Buclin, and Carlotta Guiducci. 2015. Label-free detection of tobramycin in serum by transmission-localized surface plasmon resonance. *Analytical chemistry* 87, 10 (2015), 5278–5285.
- [6] Alevtina Dubovitskaya, Visara Urovi, Imanol Barba, Karl Aberer, and Michael Ignaz Schumacher. 2016. A Multiagent System for Dynamic Data Aggregation in Medical Research. *BioMed Research International* 2016 (2016).
- [7] Alevtina Dubovitskaya, Visara Urovi, Matteo Vasirani, Karl Aberer, and Michael Ignaz Schumacher. 2015. A Cloud-based eHealth Architecture for Privacy Preserving Data Integration. In *IFIP Advances in Information and Communication Technology (SEC 2015)*. Springer Science and Business Media.
- [8] Khaled El Emam, Sam Rodgers, and Bradley Malin. 2015. Anonymising and sharing individual patient data. *bmj* 350 (2015), h1139.
- [9] 2016. Regulation (EU) 2016/679 of the European Parliament and of the Council of 27 April 2016 on the protection of natural persons with regard to the processing of personal data and on the free movement of such data, and repealing Directive 95/46/EC (General Data Protection Regulation). *Official Journal of the European Union* L119/59 (May 2016). <http://eur-lex.europa.eu/legal-content/EN/TXT/?uri=OJ:L:2016:119:TOC>
- [10] Aline Fuchs, Chantal Csajka, Yann Thoma, Thierry Buclin, and Nicolas Widmer. 2013. Benchmarking therapeutic drug monitoring software: a review of available computer tools. *Clinical pharmacokinetics* 52, 1 (2013), 9–22.
- [11] Verena Gotta, Nicolas Widmer, Michael Montemurro, Serge Leyvraz, Amina Haouala, Laurent A Decosterd, Chantal Csajka, and Thierry Buclin. 2012. Therapeutic drug monitoring of imatinib: Bayesian and alternative methods to predict trough levels. *Clinical pharmacokinetics* 51, 3 (March 2012), 187–201. DOI: <http://dx.doi.org/10.2165/11596990-000000000-00000>
- [12] Gregory William Hruby, James McKiernan, Suzanne Bakken, and Chunhua Weng. 2013. A centralized research data repository enhances retrospective outcomes research capacity: a case report. *Journal of the American Medical Informatics Association* 20, 3 (2013), 563–567.
- [13] SH Jang, Z Yan, and JA Lazor. 2016. Therapeutic drug monitoring: A patient management tool for precision medicine. *Clinical Pharmacology & Therapeutics* 99, 2 (2016), 148–150.
- [14] Roger W Jelliffe. 1991. The USC* PACK PC programs for population pharmacokinetic modeling, modeling of large kinetic/dynamic systems, and adaptive control of drug dosage regimens. In *Proceedings of the Annual Symposium on Computer Application in Medical Care*. American Medical Informatics Association, 922.
- [15] Ju-Seop Kang and Min-Ho Lee. 2009. Overview of therapeutic drug monitoring. *The Korean journal of internal medicine* 24, 1 (2009), 1–10.
- [16] James J. Lee, Jan H. Beumer, and Edward Chu. 2016. Therapeutic drug monitoring of 5-fluorouracil. *Cancer Chemotherapy and Pharmacology* 78, 3 (2016), 447–464. DOI: <http://dx.doi.org/10.1007/s00280-016-3054-2>
- [17] L. Michaelis and M. L. Menten. 1913. Die Kinetik der Invertinwirkung. 49 (1913), 333–369.
- [18] JD Momper and J A Wagner. 2014. Therapeutic Drug Monitoring as a Component of Personalized Medicine: Applications in Pediatric Drug Development. *Clinical Pharmacology and Therapeutics* 95, 2 (2014), 138–140. DOI: <http://dx.doi.org/10.1038/clpt.2013.227>
- [19] Fahima Nekka, Chantal Csajka, Mélanie Wilbaux, Sachin Sanduja, Jun Li, and Marc Pfister. 2017. Pharmacometrics-based decision tools facilitate mHealth implementation. *Expert Review of Clinical Pharmacology* 10, 1 (2017), 39–46. DOI: <http://dx.doi.org/10.1080/17512433.2017.1251837> PMID: 27813436.
- [20] Johannes H Proost and Dirk KF Meijer. 1992. MW/Pharm, an integrated software package for drug dosage regimen calculation and therapeutic drug monitoring. *Computers in biology and medicine* 22, 3 (1992), 155–163.
- [21] Charles Safran, Meryl Bloomrosen, W Edward Hammond, Steven Labkoff, Suzanne Markel-Fox, Paul C Tang, and Don E Detmer. 2007. Toward a national framework for the secondary use of health data: an American Medical Informatics Association White Paper. *Journal of the American Medical Informatics Association* 14, 1 (2007), 1–9.
- [22] Murat Sariyar and Irene Schlünder. 2016. Reconsidering Anonymization-Related Concepts and the Term "Identification" Against the Backdrop of the European Legal Framework. *Biopreservation and biobanking* 14, 5 (2016), 367–374.
- [23] A. Simalatsar, R. Bornet, Wenqi You, Y. Thoma, and G. De Micheli. 2014. Safe Implementation of Embedded Software for a Portable Device Supporting Drug Administration. In *Bioinformatics and Bioengineering (BIBE), 2014 IEEE International Conference on*. 257–264. DOI: <http://dx.doi.org/10.1109/BIBE.2014.55>
- [24] Sebastian G Wicha, Martin G Kees, Alexander Solms, Iris K Minichmayr, Alexander Kratzer, and Charlotte Kloft. 2015. TDMx: a novel web-based open-access support tool for optimising antimicrobial dosing regimens in clinical routine. *International journal of antimicrobial agents* 45, 4 (2015), 442–444.
- [25] Daniel FB Wright and Stephen B Duffull. 2011. Development of a bayesian forecasting method for warfarin dose individualisation. *Pharmaceutical research* 28, 5 (2011), 1100–1111.